

LEVELER SPECS: THREADS 1/2"-13

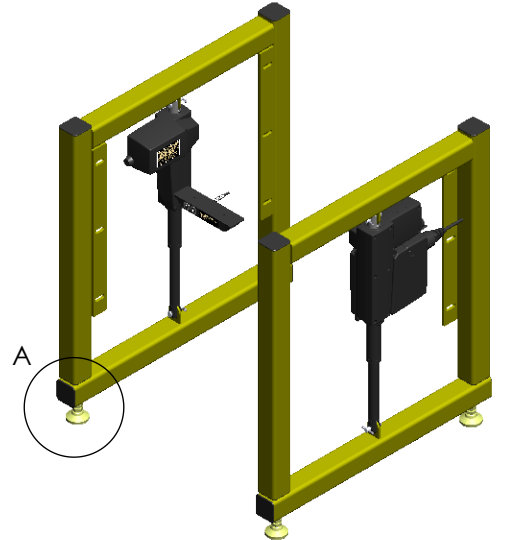

COLOR: TBD

SIZE CHART		
Base Depth	X Dim. Inch	X Dim. Metric
* Items: Actuators Rotated In		
18*	12.5 +/- .500	317.5 +/- 15
19*	13.5 +/- .500	342.9 +/- 15
20*	14.5 +/- .500	368.3 +/- 15
21*	15.5 +/- .500	393.7 +/- 15
22	16.5 +/- .500	419.1 +/- 15
23	17.5 +/- .500	444.5 +/- 15
24	18.5 +/- .500	469.9 +/- 15
25	19.5 +/- .500	495.3 +/- 15
26	20.5 +/- .500	520.7 +/- 15
27	21.5 +/- .500	546.1 +/- 15
28	22.5 +/- .500	571.5 +/- 15
29	23.5 +/- .500	596.9 +/- 15
30	24.5 +/- .500	622.3 +/- 15
31	25.5 +/- .500	647.7 +/- 15
32	26.5 +/- .500	673.1 +/- 15
33	27.5 +/- .500	698.5 +/- 15
34	28.5 +/- .500	723.9 +/- 15
35	29.5 +/- .500	749.3 +/- 15
36	30.5 +/- .500	774.7 +/- 15

Model	Width	Depth	Minimum Height	Stroke/Synchro	Floor Contact	Leveler Option
E2RF (Retro Fit Kit)	00 (N/A)	Enter Base Depth From Chart	24" (Levelers/SS) 28" (Levelers/LS)	SS (Short stroke 8", Synchronized)	L (Levelers)	AH (Anchor Hole)
			28" (Levelers/SS) 32" (Levelers/LS)	LS (Long stroke 12", Synchronized)	5 (5" Casters)	SD (Standard Duty)

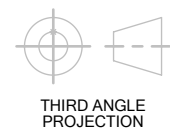

UNLESS OTHERWISE SPECIFIED ALL DRAWING UNITS ARE IN INCHES:
UNLESS OTHERWISE NOTED ALL TOLERANCES:
ANGULAR: ± X.X°
TWO PLACE DECIMAL: ± X.XX
THREE PLACE DECIMAL: ± X.XXX

INTERPRET DRAWING DETAILS PER ASME Y14.5M-1984
DOCUMENT UNCONTROLLED IF PRINTED

PART DESCRIPTION:
E2 RF-I (RETRO FIT KIT INSIDE MOUNT)
PART NUMBER:

